

VOLVO PENTA INBOARD DIESEL

NEW!

D3-110,150

81-110 kW (110-150 hp) crankshaft power acc. to ISO 8665

The new D3

Volvo Penta's new D3 has been developed using the latest available engine technology. The D3-110 & D3-150 are specially designed for displacement and semi-planing hulls. The low cruising rpm gives quiet running and low vibrations.

- Common rail system with piezo-electric injectors
- Equipped with Volvo Penta EVC-D for electronic shift & throttle



World-class performance

The 1800 bar common rail injection system with piezo-electric injectors performing multiple injections per cycle gives an extraordinary performance. The engine's high torque provides excellent operating characteristics to aid maneuvering, particularly in confined spaces.

Robust, compact and lightweight

With cast-in grey iron cylinder liners, integrated freshwater pump, and a neatly designed marinization based on Volvo Penta's unique experience, the new D3 is a very robust engine. It is ultra-compact for its swept volume and fully symmetrical, making the package very easy to install.

Aluminum cylinder block and head gives the engine a low weight for its power output.

The D3 is equipped with an engine cover that in addition to protecting the engine also gives it a modern and exclusive appearance.

Comfort

The D3 is equipped with the same type of successful engine mounts that were introduced for the D4/D6 engines. The multiple injection system in combination with the new type of engine mounts makes the engine amazingly quiet and comfortable at low speeds.

EVC-D

EVC-D, a new generation of the proven Electronic Vessel Control offers the best driver experience available!

The new ergonomically designed controls engage smoothly and allow for maneuvering with fingertip precision in any situation. Integrated pushbuttons give easy access to functions such as Cruise Control and Single Lever Control, which allows for safe and easy boating.

Complete the helm with your choice from the full range of easy to read gauges and displays including the new 7" color display. Add the trip computer function for accurate fuel management and minimized environmental impact. Engine synchronisation is of course standard in twin installations.

A propulsion package fully matched, tested and supported by one company

Volvo Penta's hydraulically shifted reverse gear has been specially developed with a view to increasing the standard of comfort on board.

The combination of 8° down angle, large drop center and small dimensions provides for optimized installations. V-drives are also available.

In order to get full benefit of the EVC system the reverse gear is equipped with electric shifting valve.

Prepared for new emission standards

The new engine has outstandingly low emissions. In addition to meeting the existing emission requirements it is prepared to meet the stringent US EPA Tier 3 regulations that will take effect in 2012.

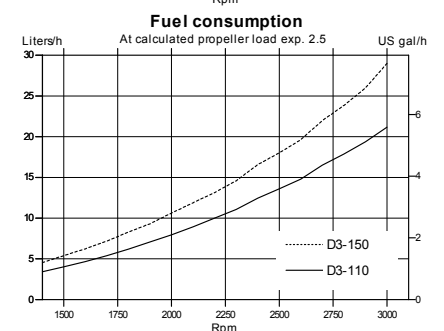
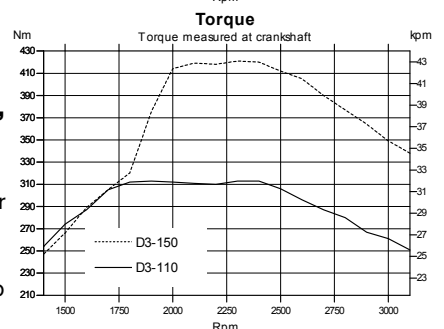
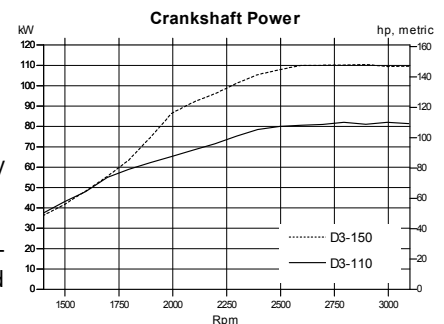

**VOLVO
PENTA**

D3-110,150

Technical description:

Engine block and head

- Cylinder block and head made of aluminum
- Cylinder block with integrated bed plate
- 4-valve technology with hydraulic lash adjusters
- Double overhead camshafts
- Oil-cooled pistons with two compression rings and one oil scraper ring
- Cast-in grey iron cylinder liners
- Replaceable valve seats
- Six-bearing crankshaft
- Front-end transmission

Engine mounting

- Flexible engine mounting

Lubrication system

- Easily replaceable (insert) full-flow oil filter
- Plate oil cooler

Fuel system

- Common rail fuel injection system
- Piezo-electric injectors
- Constant power output regardless of fuel quality or temperature (5–55°C/41–131°F)

- Fine filter with water separator and water in fuel sensor with alarm

Air inlet and exhaust system

- Replaceable air filter
- Closed crankcase ventilation with oil separator and filter
- Stainless steel exhaust elbow
- Turbocharger with variable geometry

Cooling system

- Thermostatically regulated freshwater cooling
- Tubular heat exchanger with separate large volume expansion tank
- Coolant system prepared for hot water outlet
- Easily accessible impeller pump
- Seawater strainer

Electrical system

- 12V one-pole electrical system
- 150A alternator, and integrated temperature compensated charging regulator
- Auxiliary stop button

Instruments/control

- Electronic shift and throttle
- Full range of instrumentation available

Reverse gear

HS25AE Hydraulic – drop center with 8° down angled output shaft.

- Ratio 2.48:1 or 1.92:1 (RH/LH)

HS45AE Hydraulic – drop center with 8° down angled output shaft.

- Ratio 2.43:1 or 2.03:1 (RH/LH)

HS63IVE Hydraulic V-drive.

- Ratio 2.48:1 or 1.99:1 (RH/LH).

Accessories

An extensive range of accessories are available. For detailed information, please see the Accessories & Maintenance Parts catalog (www.volvopenta.com).

Option

U.S.C.G./MED (SOLAS) kit available.

Contact your local Volvo Penta dealer for further information. Not all models, standard equipment and accessories are available in all countries. All specifications are subject to change without notice.

The engine illustrated may not be entirely identical to production standard engines.

Technical Data

Engine designation	D3-110 I	D3-150 I
Crankshaft power, kW (hp)	81 (110)	110 (150)
Propeller shaft power, kW (hp)	78 (107)	107 (146)
Engine speed, rpm	3000	3000
Displacement, l (in ³)	2.4 (146)	2.4 (146)
Number of cylinders	5	5
Bore/stroke, mm (in.)	81/93.2 (3.19/3.67)	81/93.2 (3.19/3.67)
Compression ratio	16.5:1	16.5:1
Dry weight D3-110/HS25AE, kg (lb)	297 (655)	297 (655)
Dry weight D3-150/HS45AE, kg (lb)	301 (664)	301 (664)

Duty rating: R5

Technical data according to ISO 8665. With fuel having an LHV of 42,700 kJ/kg and density of 840 g/liter at 15°C (60°F).

Merchant fuel may differ from this specification which will influence fuel consumption.

The engine complies with the comprehensive emission requirements EU RCD and US EPA Tier 2.

Prepared to meet the upcoming US EPA Tier 3 regulations.

Dimensions D3-110/HS25AE and D3-150/HS45AE

Not for installation

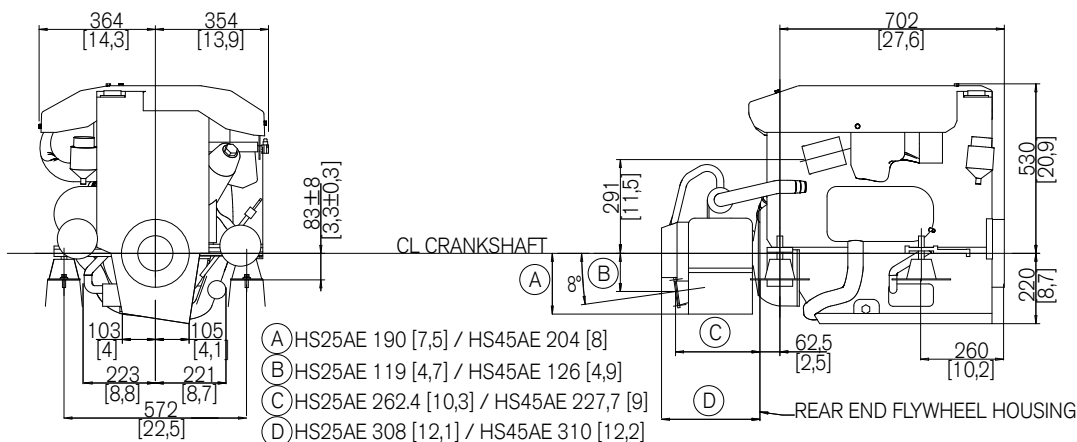

VOLVO PENTA

AB Volvo Penta

SE-405 08 Göteborg, Sweden
www.volvopenta.com