

VOLVO PENTA INBOARD DIESEL

D3-110

81 kW (110 hp) crankshaft power acc. to ISO 8665

Power for high onboard comfort

Volvo Penta's 5-cylinder D3-110 is specially matched for displacement and semi-planing hulls, developed from the latest design in modern diesel technology. The low cruising rpm gives quiet running and low vibrations. The engine is very lightweight and compact. All these features contribute to exceptional comfort and world-class diesel performance, combined with low emissions.



World-class performance

The common rail fuel injection system, electronically controlled, in combination with the large swept volume and Variable Geometry Turbine (VGT), ensures outstanding torque during acceleration, with virtually no sign of smoke. The engine's high torque provides excellent operating characteristics to aid maneuvering, particularly in confined spaces.

Low weight

The engine has an extremely low weight for its power output. This thanks to the all aluminum base engine and a highly efficient marinization.

The engine is fitted with freshwater cooling as standard for long service life.

Compact

The engine is ultra-compact for its large swept volume. With cast-in grey iron cylinder liners, integrated freshwater pump, a compact marinization, and a fully symmetric engine, the package simply gets that compact.

Comfort

The rigid aluminum cylinder block and bed plate in wedge structure, and exactly controlled high-pressure fuel injection combined with low cruising rpm gives excellent onboard comfort with low noise and vibration levels.

EVC/MC - Plug and go

EVC Electronic Vessel Control is the latest development in instrumentation for marine engines with mechanical shift and throttle.

With EVC/MC you can tailor the instrumentation to fit the boat, from a single EVC system tachometer, where you can read all engine/boat data, to a dashboard full with standard gauges and an EVC system display, or any combination in between. EVC/MC also offers an optional multi-sensor to read speed, depth and surface water temp.

The system is built on the latest automotive technology with waterproof connectors, so it's just plug and go. EVC works closely together with the engine management system offering you constant power output regardless of temperature (5–55°C / 41–131°F) and quality of the fuel.

Reverse gear

Volvo Penta's hydraulically shifted reverse gears have been specially developed with a view to increasing the standard of comfort on board in terms of quiet running, greater reliability and enhanced efficiency.

The combination of 8° down angle, large drop center and small dimensions provides for optimized installations.

At Volvo Penta, focus is on developing the complete drive line ensuring perfectly matched engine/transmission packages.

Meeting new emission standards

The common rail injection system in combination with electronics and an advanced combustion system are setting new standards in minimizing noxious emissions and particulates. The engine complies with the comprehensive emission requirements EU RCD and US EPA Tier 2.

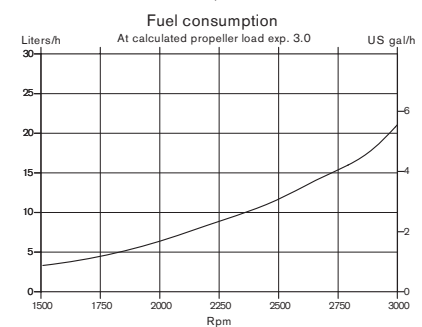
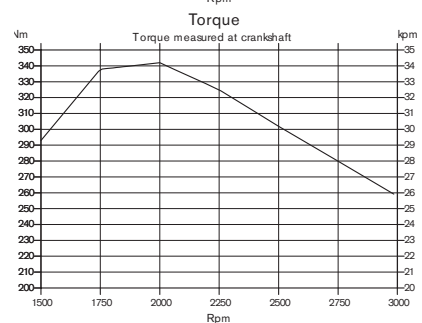
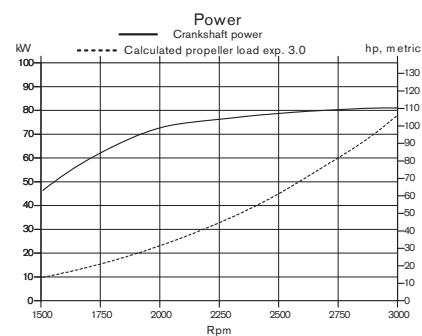

**VOLVO
PENTA**

D3-110

Technical description:

Engine block and head

- Cylinder block and cylinder head made of aluminum
- Cylinder block with integrated bed plate
- 4-valve technology with hydraulic lash adjusters
- Double overhead camshafts
- Oil-cooled pistons with two compression rings and one oil scraper ring
- Cast-in grey iron cylinder liners
- Replaceable valve seats
- Six-bearing crankshaft
- Front-end transmission

Engine mounting

- Flexible engine mounting

Lubrication system

- Easily replaceable (insert) full-flow oil filter
- Plate oil cooler

Fuel system

- Common rail fuel injection system
- Control unit for processing the injection
- Fine filter with water separator

Air inlet and exhaust system

- Air filter with replaceable insert
- Closed crankcase ventilation with oil separator of cyclone type
- Exhaust elbow of stainless steel
- Turbocharger with variable geometry

Cooling system

- Thermostatically regulated freshwater cooling
- Tubular heat exchanger with separate large volume expansion tank
- Coolant system prepared for hot water outlet
- Easily accessible impeller pump

Electrical system

- 12V one-pole electrical system
- 140A alternator, and integrated temperature compensated charging regulator
- Auxiliary stop button

Instruments/control (options)

- Mechanical shift and throttle
- Basic instrumentation including key switch and interlocked alarm
- Plug-in connections

Reverse gear

- HS25A** Hydraulic – drop center with 8° down angled output shaft. Trolling valve kit available.
 - Ratio 2.48:1 or 1.92:1 (RH/LH)
- HS45A** Hydraulic – drop center with 8° down angled output shaft. Trolling valve kit available.
 - Ratio 2.43:1 or 2.03:1 (RH/LH)
- HS63IV** Hydraulic V-drive. Trolling valve kit available.
 - Ratio 2.48:1 or 1.99:1 (RH/LH)

Accessories

An extensive range of accessories are available. For detailed information, please see the Accessories & Maintenance Parts catalog (www.volvopenta.com).

Contact your local Volvo Penta dealer for further information.

Not all models, standard equipment and accessories are available in all countries. All specifications are subject to change without notice.

The engine illustrated may not be entirely identical to production standard engines.

Technical Data

Engine designation	D3-110 I
Crankshaft power, kW (hp)	81 (110)
Propeller shaft power, kW (hp)	78 (106)
Engine speed, rpm	3000
Displacement, l (in ³)	2.4 (146)
Number of cylinders	5
Bore/stroke, mm (in.)	81/93.2 (3.19/3.67)
Compression ratio	17.3 :1
Dry weight with HS25A, kg (lb)	264 (582)

Duty rating: R5

Technical data according to ISO 8665. With fuel having an LHV of 42,700 kJ/kg and density of 840 g/liter at 15°C (60°F). Merchant fuel may differ from this specification which will influence engine power output and fuel consumption. The engine complies with the comprehensive emission requirements EU RCD and US EPA Tier 2.

Dimensions D3-110/HS25A

Not for installation

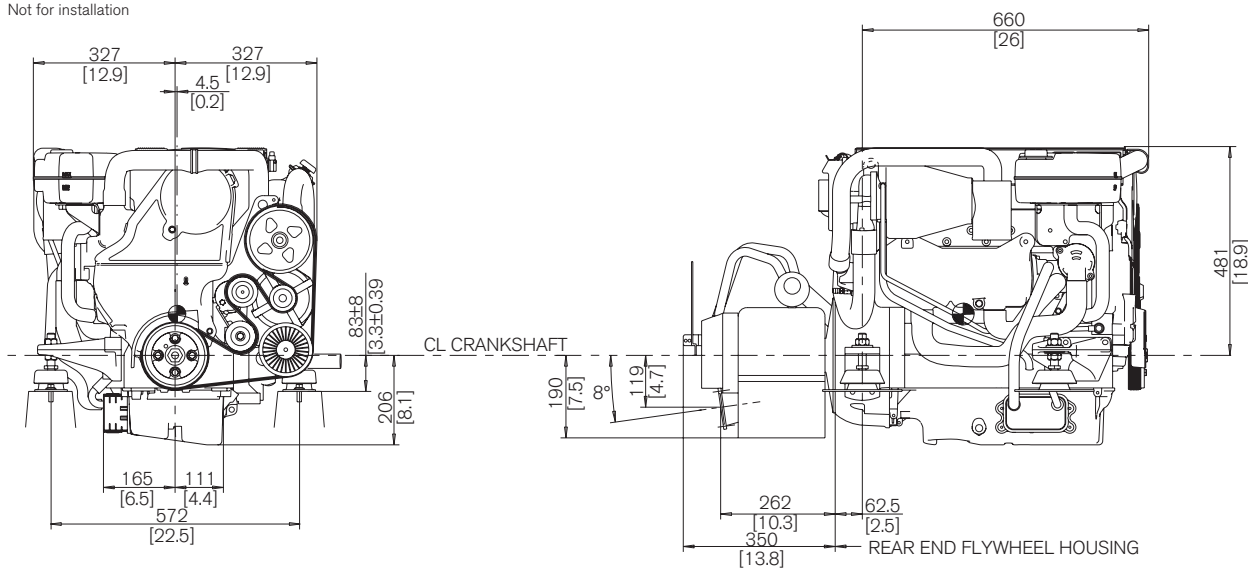

VOLVO PENTA

AB Volvo Penta
SE-405 08 Göteborg, Sweden
www.volvopenta.com